

## Typical Consumer Interface Unit - Bottom Entry WK1 Compact

### Hydraulic Diagram

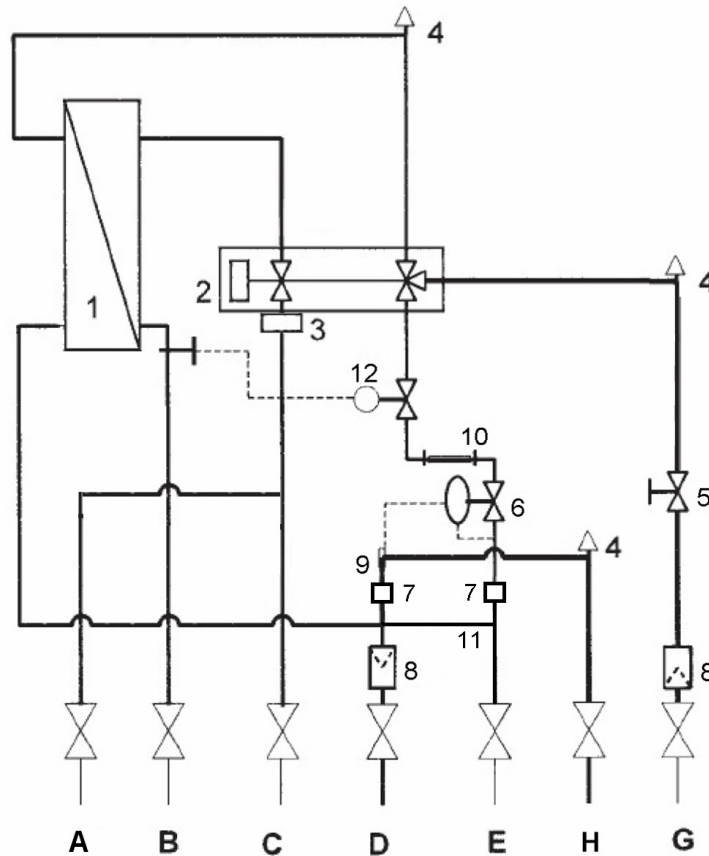

### Surface Mounted Cabinet

White, polyester powder coated, RAL 9016

Dimensions: 480mm x 800mm x 165mm (Width x Height x Depth)

### **Duties Example**

Duty (Primary) Domestic Hot Water Mode	Heat Transfer Capacity Flow Rate Fluid Temp On Fluid Temp Off	35 kW 0.15 kg/s 80 °C 24 °C
Duty (Secondary) Domestic Hot Water service	Heat Transfer Capacity Flow Rate Fluid Temp On Fluid Temp Off	35 kW 0.21kg/s 10 °C 50 °C
Duty (Secondary) Heating	Capacity Max Pressure Drop (HIU+Radiator Circuit) Flow Rate Fluid Temp On Fluid Temp Off	10 kW 15 Kpa 0.06 kg/s 80 °C 40 °C
Pressure	Primary Working Primary Test Secondary Working Secondary Test	6.0 bar 10.0 bar 3.0 bar 7.0 bar
Connections	Primary Flow Primary Return Secondary DHW Flow Secondary Heating Flow Secondary Heating Return	20 mm 20 mm 22 mm 22 mm 22 mm

1. Stainless Steel Plate Heat Exchanger
2. PM Control Valve
3. Cold Water Flow Regulator
4. Manual Air Vent
5. Actuated 2 Port Control Valve 230V
6. Differential Pressure Regulator
7. Binder Test Points
8. Filter
9. ½" Internal Thread Coupling for heat meter –  
Thermometer Pocket
10. Kamstrup Heat Meter
11. Primary Bypass
12. Thermostatic Hot Water Temperature Regulator

- A. Domestic Cold Water Supply to Apartment
- B. Domestic Hot Water supply to Apartment
- C. Boosted Cold Water from Riser
- D. Primary Flow
- E. Primary Return
- H. Apartment Heating – Flow
- G. Apartment Heating – Return